

M720 pH/ORP Controller

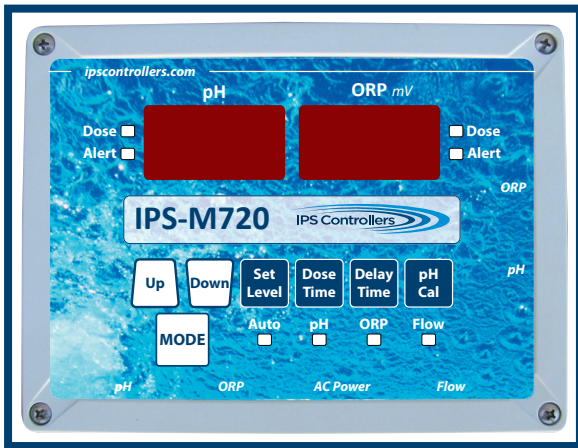

Owner's Manual



Simply intelligent water care.

Table of Contents

- I. Introduction page 2
- A. Water Chemistry page 2
- B. Safety page 3
- C. System Components page 4
- D. Specifications page 7
- E. Controller Panel Descriptions page 8
- F. Electrical Descriptions page 10

- II. Installation page 11
- A. Setup page 11
- B. Tools page 11
- C. Procedure page 11

- III. Operation page 14
- A. Startup and Shutdown page 14
- B. Modes and Adjustments page 15
- C. Maintenance page 23

- IV. Troubleshooting page 25

- V. Warranty page 28



Certified to
NSF/ANSI Standard 50

I. Introduction

A. Water Chemistry

Water chemistry is a complex science that contains many variables. These variables not only affect the water environment itself, but they can have adverse effects on your equipment as well as your health. These are only some of the factors which we follow closely to ensure the most healthy water interactions:

pH is the measurement of the acidity or basicity in an aqueous solution. A measurement below 7 is considered acid, while a measurement above 7 is base or alkaline. It is a significant factor in determining the water quality as it affects sanitizer levels, water color, and human reaction to the water.

ORP (Oxidation Reduction Potential) is the measurement of the oxidizing capacity present in water. ORP cannot be fooled by the effects of pH, total dissolved solids (TDS), stabilizers, and non-chlorine oxidizers. A typical ORP sensor measures Hypochlorous Acid (HOCl), which is the more effective component of free chlorine. A higher ORP reading equates to the sanitizer working more effectively.

Water balance is comprised of pH, calcium hardness, total alkalinity, temperature, and TDS. When water is balanced, the Langelier saturation index is 0. Values above +0.3 lead to scaling and cloudy water, while values below -0.3 can cause corrosion of pool equipment and surfaces. If the water balance is not fixed in a timely manner, secondary effects can lead to rapidly declining water conditions that can affect the health of the water occupants.

pH and ORP work conversely to one another, and are affected by other factors such as temperature and TDS' that can increase the negative impacts of unbalanced water.

B. IMPORTANT SAFETY INSTRUCTIONS

1. READ AND FOLLOW ALL INSTRUCTIONS.

2. **Risk of electric shock:** Connect the controller to a dedicated ground-fault circuit interrupter (GFCI) circuit breaker.
3. Disconnect power before servicing the controller.
4. Inspect all power cords frequently. Any damaged cords should be replaced immediately to reduce the risk of injury by shock.
5. Always maintain a record of manual water chemistry readings using an accurate test kit.

6. **WARNING** — To reduce the risk of injury, do not permit children to use this product unless they are closely supervised at all times.

7. Danger — Risk of injury.
 - a. Replace damaged cord immediately.
 - b. Do not bury cord.
 - c. Connect to a grounded, grounding type receptacle only.

8. **WARNING** — Risk of electric shock. Install at least 5 feet (1.5m) from inside wall of water enclosure using non-metallic plumbing.

9. Operation of this controller without a functioning flow-switch will void the NSF Certification.

10. **WARNING** — Do not install this controller where it is accessible to the public.

11. SAVE THESE INSTRUCTIONS.

C. System Components

1. IPS M720 pH/ORP Controller

- a. Allows automatic monitoring of pH and ORP levels through a simple, user-friendly interface, resulting in easier management of water balance in swimming pools, spas, or circulating water environments.
- b. Can be easily installed into your existing pool environment and equipment, or can be customized to your needs.
- c. Monitors and displays the pH and ORP levels using LEDs and digital readouts on the front panel.

In addition, five separate function buttons allow simple pushbutton control of these individual parameters:

- 1) Mode - Auto or pH Standby (programming),
 - 2) Set Level - pH level to be maintained,
 - 3) Dose Timer - Timed or Continuous feed modes,
 - 4) Delay Time - Delay period after each Dose Time,
 - 5) pH Cal - pH calibration.
- d. When the pH level rises above (acid feed) or falls below (base feed) the set level, the controller will activate the chemical feeder for the set dose time. Then the set delay time will occur. This dose and delay time will occur until the set level is reached.
 - e. When the ORP (sanitizer) level reaches the set level, the controller will activate the chemical feeder for the set dose time. Then the set delay time will occur. This dose and delay time will occur until the set level is reached.

2. Flow Cell with Flow Switch

- a. An injection-molded flow cell with integrated flow-switch houses the pH and ORP sensors, and partners with the M720 controller to monitor the pH and ORP levels in the water.

- b. The flow switch verifies that water is flowing during a feed cycle, and sends the controller instructions to deactivate the feed if water is not flowing.
 - c. Operation of this controller without a functioning flow-switch will void the NSF Certification. Routinely check that the flow-switch is functioning by closing the left valve on the bottom of the flow-cell (flow light should turn off).
3. pH and ORP Sensors
- a. pH Sensor – standard (Use only IPS Controllers part # SXPB to maintain NSF Certification)
 - b. ORP Platinum Sensor – standard (Use only IPS Controllers part # SXORP to maintain NSF Certification)
 - c. ORP Gold Sensor - for use with Salt Chlorine systems (Use only IPS Controllers part # SXORP-G to maintain NSF Certification)
4. Fittings – for tapping installation of flow cell input/output
5. In-line Filter – installed prior to flow cell to protect flow switch and sensors
6. Tubing – 25 feet of 3/8" for providing filtered water to and from the flow cell
7. Mounting Board – ABS plastic with mounting holes and stainless hardware (16" x 12" standard, 24" x 19" optional)
8. Chemical Feeders – peristaltic pumps for pH and ORP control (purchased separately)

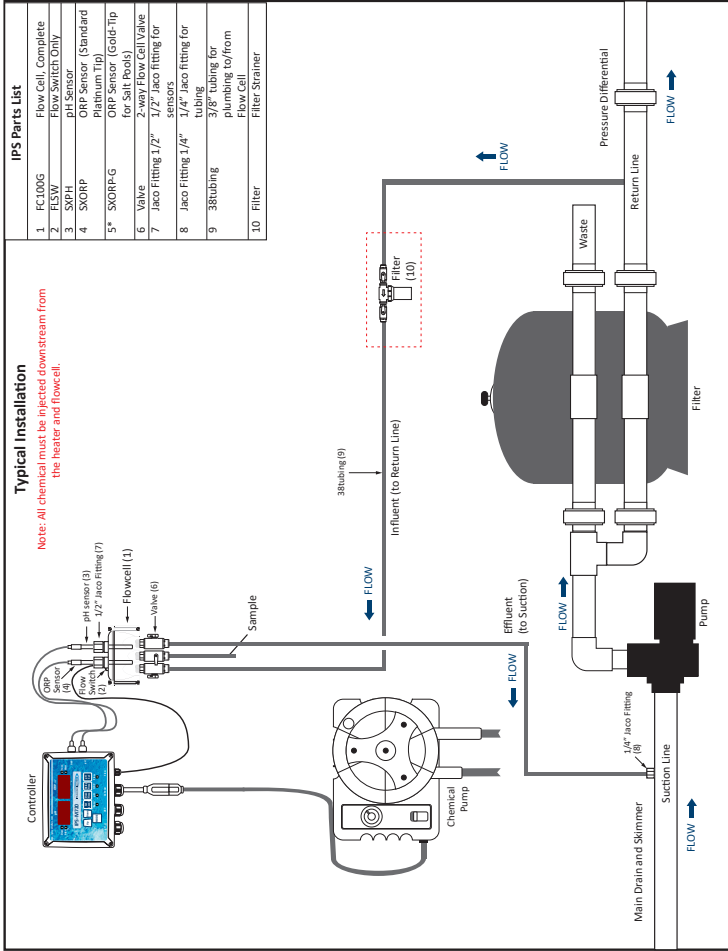

Figure 1: This is a typical installation using IPS' system package, which consists of an M720 pH/ORP Controller, flow cell with switch, and two pumps mounted on the large board.

D. Specifications

Enclosure: 6.375"L x 4.75"W x 3.5"D (**Note:** Mounting board dimensions are 16"L x 12"W x 0.25"D)

Electrical Input/Output: 110/230 VAC, 50 - 60 Hz

pH Set Level: 7.0 to 8.0

ORP Set Level: 400 mV to 900 mV

Dose Time: Off, Continuous, or Timed cycle

High Alert: pH default of 8.0, ORP default of 900

Low Alert: pH default of 7.0, ORP default of 100

Readout: Function LED and numerical digital displays

Alarm: Red alert LEDs

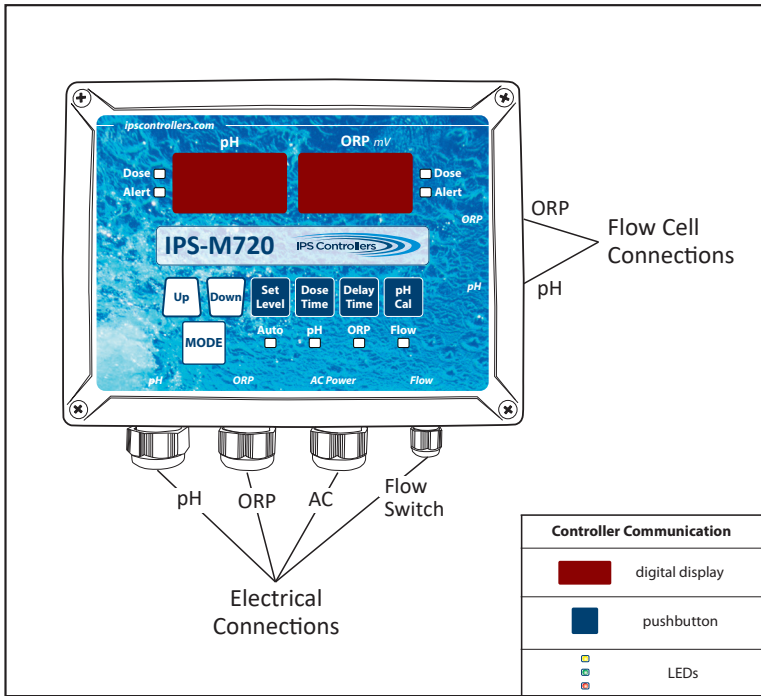

Figure 2: M720 Controller Components Connections

E. Controller Panel Descriptions

1. Digital Displays and Function LEDs
 - a. pH
 1. Alert - red LED
 2. Dose - green LED
 - b. ORP
 1. Alert - red LED
 2. Dose - yellow LED

2. Mode - pushbutton adjustments
 - a. Auto - red LED
 - b. pH standby - green LED
 - c. ORP standby - yellow LED
 - d. OFF mode - In standby, press and hold Mode button for 3 seconds to turn controller off.
3. Flow - green LED
4. Up/Down button to adjust the following:
 - Set Level
 - Dose Time
 - Delay Time
 - pH Cal
5. Electrical Connections (peripherals)
 - a. pH output (left receptacle) - max. 5 amps @ 110/230 VAC
 - b. ORP output (right receptacle) - max. 5 amps @ 110/230 VAC
 - c. AC power - 110/230 VAC, 50-60 Hz
 - d. Flow - from flow cell
 - e. pH sensor - BNC connection
 - f. ORP sensor - BNC connection

F. Electrical Descriptions

1. Power
 - a. 110/230 VAC, 50-60 Hz, 3-wire grounded NEMA 5 power cord. GFCI source required.
2. Dip Switches (1-4)
 - a. 1: pH/ORP interlock (default: **OFF**)
No ORP feed if pH is feeding (ON).
 - b. 2: pH/ORP alert interlock (default: **ON**)
No ORP if pH is in alert mode (ON).
 - c. 3: Acid/Base default acid (default: **OFF**)
 1. Feed base chemical when pH level falls below set point. (ON)
 2. Feed acid chemical when pH above set point. (OFF)
 - d. 4: Over Timer ON/OFF (default: **ON**)
Note: Turning off the Over Timer will void any NSF Certification.

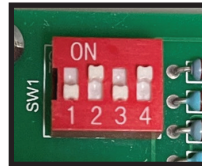

Figure 3: Dipswitches

II. Installation

A. Setup

1. Turn off all peripheral equipment such as heaters, chemical feeders, and pumps.
2. Relieve pressure from the filtration system.

B. Tools

1. Cordless drill
2. 1/4" NPT Tap
3. 7/16" drill bit
4. Masonry drill bit and anchors, or other appropriate fasteners
5. 13/16" wrench or channel-lock pliers

C. Procedure

1. Location
 - a. Wall area with easy access
 - b. Within 8 feet of feeder
 - c. At least 10 feet from water edge
 - d. Close proximity to time clock
 - e. Within 6 feet of GFCI power source

2. Mounting

Note: The controller and flow cell are factory mounted to the ABS board for convenience.

- a. Securely mount ABS mounting board with M720 controller and flow cell on wall (vertical installation).
- b. If applicable, securely attach the peristaltic pump with the provided hardware.

- c. Drill a 7/16" hole and tap a 1/4" NPT port to a location downstream from the filter and upstream from any chemical introduction points. Install a tubing connector (included) and flex tubing to be connected to the left side flow cell port containing the flow switch. The in-line filter will also be installed in this line and mounted to a horizontal pipe with band clamps (included). **Note: Verify that the filter is installed with directional arrows pointing in the direction of the flow.**
- d. Drill a 7/16" hole and tap a 1/4" NPT port to a location that is subject to vacuum or reduced pressure. Install a tubing connector (included) and flex tubing to be connected to the right side flow cell port. **Note: We recommend that this tubing connector be installed into the drain hole on the suction side of the pump for best performance.**
- e. Cut a 3" - 6" length of flex tubing and insert into the flow cell's sample stream port (center).

3. pH and ORP Sensors

Note: Carefully unpack the pH and ORP sensors and set aside in a clear area until ready to install into the flow cell.

- a. Verify that the M720 controller power is OFF.
- b. Carefully remove the plastic protective caps from the sensors and store in a separate location for future re-use.
- c. Slide the glass end of each sensor (pH and ORP) into their corresponding compression fittings located at the top of the flow cell. Ensure that the tip is submerged into the water to within 1/2" from the bottom of the flow cell. Hand tighten each nut fitting.

4. Electrical Connections (Should be completed by a licensed Electrician)
 - a. Verify that the M720 controller power is OFF.
 - b. Connect the pH feeder connection to the appropriate peristaltic pump or other device.
 - c. Connect the ORP feeder connection to the appropriate peristaltic pump or other device.
 - d. Connect the AC power cord to a GFCI power source. For outdoor installations, ensure the use of a watertight outlet cover.
 - e. Connect the blue pH sensor connector to the corresponding port (labeled pH) at the right edge of the controller.
 - f. Connect the yellow (or green) ORP sensor connector to the corresponding port (labeled ORP) at the right edge of the controller.

III. Operation

A. Startup and Shutdown

1. Startup

- a. Plug M720 power cord into power outlet. For outdoor installations, ensure the use of a watertight outlet cover.
- b. Turn on the filter pump and verify the water flow through the flow cell by opening the sample port valve (center) and observing a steady stream of water. The right side valve may need to be partially closed to produce a steady stream. **Note: Water should pass over the pH and ORP sensors for a minimum of 10 minutes to allow for accurate, stable readings of pH and ORP levels from the pool or spa.**
- c. Check for leaks and repair if necessary.
- d. Manually adjust and balance the pool or spa water to acceptable ranges using a DPD-based test kit.
- e. Verify that the green Flow LED is illuminated. Both the pH and ORP dose outputs are disabled if there is no water flow.
- f. Press the Mode pushbutton momentarily to place the controller into the pH standby mode. The green pH standby LED will illuminate. Select the desired pH set level and dose time (continuous or timed). Please call us at 877-693-6903 for assistance with initial settings.
- g. While still in the pH standby mode, press the pH Cal pushbutton to calibrate the reading to the value observed through the manual testing of the water. **Note: Always calibrate using water from the sample port of the flow cell.**

- h. Press the Mode pushbutton momentarily to place the controller in ORP standby mode. The yellow ORP standby LED will illuminate. Select the desired ORP set level and dose time (continuous or timed). Please call us at 877-693-6903 for assistance with initial settings.
- i. Press the Mode pushbutton momentarily until the red Auto LED is illuminated. **Note: If pH level in the pool is at desired set level, and chlorine/bromine level is at desired PPM level in the pool, the ORP set level should be the same as the current ORP reading when in Auto Mode.**

2. Shutdown

Note: Each time the Mode pushbutton is momentarily pressed, the mode will cycle from Auto to pH Standby to ORP Standby, and then return to Auto mode.

- a. Press the Mode pushbutton momentarily to place the controller in pH standby mode. The green pH standby LED will illuminate, and both the pH and ORP digital displays will show dashes.
- b. Press and hold the Mode pushbutton for 2 seconds until both the pH and ORP digital displays read OFF.
- c. Release the Mode pushbutton. The M720 controller will turn off, and the digital displays and function LEDs will go blank. The green Flow LED will be illuminated if water is flowing through the flow cell.

B. Modes and Adjustments

1. Auto

- a. This is the normal operational mode of the M720 controller.
- b. The controller allows full operation and monitoring of both pH and ORP levels.
- c. No function pushbuttons are operational in this mode.
- d. The red function LED next to Auto is illuminated.
- e. pH and ORP digital displays monitor the sensor input levels.

2. pH standby

Note: While in this mode, the green pH standby LED will illuminate, both the pH and ORP digital displays will show dashes, and all Auto functions will be disabled. When a function pushbutton is pressed, the corresponding digital display will show the function.

- a. Set Level
 1. Default: 7.4 pH
 2. Selectable range: 7.0 – 8.0 pH (in 0.1 increments)
- b. Dose Time
 1. Default: Timed dose of 10 second pH feed relay energized and 5 minutes pH feed relay de-energized. In the timed dose cycle mode, the Dose LED will flash while dosing and illuminate steadily during the delay portion of the timed cycle. In continuous dose mode, the Dose LED will flash while dosing.
 2. Selectable range: OFF, CON (continuous), and Timed (0.6 – 900 seconds ON and 5 minutes OFF)
- c. Delay Time
 1. Default is a 5-minute delay after dosing
 2. Selectable range 1 – 99 minutes
- d. Over Timer
 1. Preset: 60 timed cycles or 60 minutes in continuous feed.
 2. Selectable range in timed feed: OFF, 20 – 100 feed cycles. Selectable range in continuous feed: OFF, 20 – 180 minutes.
 3. Changing Over Timer setting
 - i. Press Mode button to enter pH standby
 - ii. Press and hold Mode button and then press Delay Time button (red pH alert LED will come on) release both buttons. You are now in Set Over Timer mode.

- iii. Use Up/Down button to increase/decrease Over Timer
 - iv. When finished, press Mode button to continue
 - 4. The Over Timer is interlocked with the Dose Time selection.
 - i. If the Dose Time is set to a timed cycle, the Over Timer will count timed feed cycles. Every time the set level is reached the timer will reset its count. If the preset cycle is reached, the pH digital display will flash, and the pH output relay will de-energize. The controller must be reset manually by cycling out of and back into Auto mode using the mode button. (Default: 60 cycles)
 - ii. If the Dose Time is set to a continuous feed mode, the Over Timer will count in minutes. (Default: 60 minutes)
 - 5. When the Dose Time is changed from either timed or continuous feed, the Over Timer is reset to Default.
- e. High Alert - Default: 8.0 pH
- 1. Default: 8.0 pH
 - 2. Selectable range: OFF, 7.5 pH to 8.4 pH (acid feed). A high alert will occur if the pH level remains above the High Alert level for 10 continuous minutes, and will automatically turn off the High Alert when the pH level falls below the high alert level for 1 continuous minute. During High Alert, the pH dose output will be disabled.
 - 3. Changing High Alert setting
 - i. Press Mode button to enter pH standby
 - ii. Press and hold Mode button and then press Set Level button (red pH alert LED will come on) release both buttons. You are now in Set Alerts mode.
 - iii. Press Set Level button again to display current High Alert

- iv. Use Up/Down button to increase/decrease pH High Alert
 - v. When finished, press Mode button to continue
 - f. Low Alert
 - 1. Default: 7.0 pH
 - 2. Selectable range: OFF, 6.8 pH to 7.4 pH (acid feed). A low alert will occur if the pH level remains below the Low Alert level for 10 continuous minutes, and will automatically turn off the Low Alert when the pH level rises above the low alert level for 1 continuous minute. During Low Alert, the pH dose output will be disabled.
 - 3. Changing Low Alert setting
 - i. Press Mode button to enter pH standby
 - ii. Press and hold Mode button and then press Set Level button (red pH alert LED will come on) release both buttons. You are now in Set Alerts mode.
 - iii. Press Dose Time button to display current Low Alert
 - iv. Use Up/Down button to increase/decrease pH Low Alert
 - v. When finished, press Mode button to continue
- 3. pH Cal
 - 1. Allows pH reading to be adjusted .9 pH up or .9 pH down from actual sensor reading.
 - 2. Default: 0 pH adjustment
 - 3. To clear all calibration that may have been entered:
 - i. Press Mode button to enter pH standby
 - ii. Press and hold Mode until the controller turns off.
 - iii. Press and hold the pH Cal button and then the Mode button until the controller turns on. Release both buttons.
 - iv. Press the Mode button to continue back to Auto to see the reading without calibration.

4. ORP standby

Note: While in this mode, the yellow ORP standby LED will illuminate, both the pH and ORP digital displays will show dashes, and all Auto functions will be disabled. When a function pushbutton is pressed, the digital display will show the function.

a. Set Level

1. Default: 650 mV
2. Selectable range: 400 mV to 900 mV (in 5 mV increments)

b. Dose Time

1. Default: 10 second ORP feed relay energized and 5 minutes ORP feed relay de-energized (timed Dose Time). In the timed dose cycle mode, the dose LED will flash while dosing, and will illuminate steadily during the delay portion of the timed cycle. In continuous dose mode, the dose LED will flash while dosing.
2. Selectable range: OFF, CON (continuous), and Timed (0.6 to 900 seconds ON and 5 minutes OFF)
3. Delay Time
 - i. Default is a 5-minute delay after dosing
 - ii. Selectable range 1 – 99 minutes

c. Over Timer

1. Default: 60 Cycles timed feed, 60 minutes continuous feed
2. Selectable range in timed feed: OFF, 20 – 100 feed cycles. Selectable range in continuous feed: OFF, 20 – 180 minutes.
3. Changing Over Timer setting
 - i. Press Mode button to enter ORP standby

- ii. Press and hold Mode button and then press Delay Time button (red ORP alert LED will come on) release both buttons. You are now in Set Over Timer mode.
 - iii. Use Up/Down buttons to increase/decrease Over Timer
 - iv. When finished, press Mode button to continue
 4. The Over timer is interlocked with the Dose Time selection.
 - i. If the Dose Time is set to a timed cycle, the Over Timer will count timed feed cycles. Every time the set level is reached the timer will reset its count. If the preset cycle count is reached, the pH digital display will flash, and the pH output relay will de-energize. The controller must be reset manually by cycling out of and back into Auto mode using the mode button (Default: 60 cycles)
 - ii. If the Dose Time is set to a continuous feed mode, the Over Timer will count in minutes. (Default: 60 minutes)
 5. When the Dose Time is changed from either timed or continuous feed, the Over Timer is reset to Default.
- d. High Alert
1. Default: 900 mV
 2. Selectable range: 650 mV to 900 mV, no OFF. A high alert will occur if the ORP level remains above the High Alert level for 10 continuous minutes, and will automatically turn off the High Alert when the ORP level falls below the high alert level for 1 continuous minute. During High Alert, the ORP1 dose output will be disabled.
 3. Changing High Alert setting
 - i. Press Mode button to enter ORP standby

- ii. Press and hold Mode button and then press Set Level button (red ORP alert LED will come on) release both buttons. You are now in Set Alerts mode.
 - iii. Press Set Level button again to display current High Alert
 - iv. Use Up/Down button to increase/decrease ORP High Alert
 - v. When finished, press Mode button to continue
 - e. Low Alert
 - 1. Default: 100 mV
 - 2. Selectable range: OFF, 100 mV to 640 mV. A low alert will occur if the ORP level remains below the Low Alert level for 10 continuous minutes, and will automatically turn off the Low Alert when the ORP level rises above the low alert level for 1 continuous minute. During Low Alert, the ORP1 dose output will be disabled.
 - 3. Changing Low Alert setting
 - i. Press Mode button to enter ORP standby
 - ii. Press and hold Mode button and then press Set Level button (red ORP alert LED will come on) release both buttons. You are now in Set Alerts mode.
 - iii. Press Dose Time button to display current Low Alert
 - iv. Use Up/Down button to increase/decrease ORP Low Alert
 - v. When finished, press Mode button to continue
 - f. pH Cal disabled
5. Flow
- a. The controller and flow cell are shipped pre-mounted to a small (16" x 12") or large (24" x 19") ABS plastic board. The integrated flow switch is pre-wired to the controller.

- b. The flow switch must be installed for safety reasons to prevent dosing chemicals when there is no flow in the circulation piping.

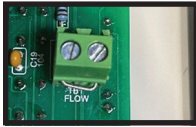

Figure 4: Flow Switch Jumper

6. Factory defaults

To return the controller to the factory defaults:

- a. Place the controller in pH Standby Mode.
- b. Turn off the controller by holding down the Mode pushbutton.
- c. Press and hold both the Set Level and pH Cal pushbuttons, and then press the Mode pushbutton.
- d. The pH display will show “Ld” and the software version number will display in the ORP window.
- e. The controller will be returned to the factory default functions, and be placed in the test mode.
- f. Return the controller to full operation by turning off the controller with the Mode pushbutton. Turn the controller on again by pressing the Mode pushbutton. **Note: Failure to complete this action will leave the controller in the test mode.**

C. Maintenance

1. Winterizing (extended shutdowns or colder climates)
 - a. Turn off the M720 controller and shut off main power to controller.
 - b. Gently remove the pH and ORP sensors from the flow cell. Fill the provided protective caps (removed during installation) with water and re-install onto each sensor, and store in a warm, secure location.
 - c. Drain the water from the flow cell.

2. Cleaning the sensor tips

Note: It is important to keep the sensor tips clean in order to ensure accurate readings.

- a. Sensor tips should be cleaned every 1 to 3 months for commercial pools and spas, and every 3 to 6 months for residential pools and spas. Determine the necessary frequency by comparing the readings before and after the cleaning. Identical readings mean that the cleaning time can be extended.
- b. Turn off the M720 controller.
- c. Close the right and left valves at the bottom of the flow cell.
- d. Loosen the nut fitting on the sensor and gently remove it from the flow cell.
- e. Swirl the sensor tip for 5 seconds in Muriatic acid or white vinegar and rinse with water. **Note: Do not touch or brush the sensor tip.**
- f. *For commercial pools and spas:* For every 3rd cleaning, swirl the sensor tip in a liquid soap and water solution. Rinse with water.
- g. Gently re-insert the sensor into the flow cell and hand tighten the nut fitting.

- h. Turn on the M720 controller.
- i. Open the flow cell valves and wait for a few minutes for the system to stabilize and get an accurate reading. Adjust the Set Level if necessary.
- j. If the sensor does not show the indicated readings, then it must be replaced.

IV. Troubleshooting

A. pH level too low or Alert LED on

1. *pH Set level is too low:* Check pH level with test kit and adjust Set Level as necessary.
2. *Chemical dose time too high:* Lower dose time.
3. *Chemical feeder is empty (base):* Refill the feeder.
4. *Sensor malfunction:* Replace sensor.

*Low alkalinity can also cause pH to drift to lower levels.
Always target 80-120ppm

B. pH level too high or Alert LED on

1. *Sensor tip is dirty:* Clean according to maintenance instructions.
2. *Improper pH sensor calibration:* Adjust pH calibration.
3. *Chemical tank is empty (acid):* Refill the tank.
4. *Chemical Feed pump or squeeze tube malfunction:* Repair the feed pump or replace the squeeze tube. A squeeze tube will last 3-6 months for commercial properties and 6-12 months for residential properties.
5. *Chemical dose time too low:* Increase dose time.

*High alkalinity will require more acid than usual to maintain pH levels. Always target 80-120ppm

C. Chlorine/Bromine level too low or Alert LED on

1. pH should be at your desired set level before addressing any potential ORP problems
2. *ORP Set level is too low:* Check Sanitizer level with test kit and adjust Set Level as necessary
3. *Controller undershooting set level:* 1) Check for proper valve positions and leaks in chlorine lines, or 2) Increase dosing time

if using timed feed, or switch to continuous feed if using a salt chlorine generator.

4. *Chemical dose time too low:* Increase the dose time.
5. *Chemical feeder is empty:* Refill the feeder.
6. *Chemical check valve/injector is clogged:* Switch acid feed tube to chlorine injector to clean.
7. *Chemical Feed pump or squeeze tube malfunction:* Repair the feed pump or replace the squeeze tube. A squeeze tube will last 3-6 months for commercial properties and 6-12 months for residential properties.
8. *Sensor malfunction:* Replace sensor.

D. Chlorine/Bromine level too high or Alert LED on

1. pH should be at your desired set level before addressing any potential ORP problems.
2. *ORP Set level is too high:* Check Sanitizer level with test kit and adjust Set Level as necessary.
3. *Controller overshooting set level:* Lower dosing time, or switch from continuous feed to timed feed.
4. *Problem with chlorine supply:* 1) Verify that the chlorine feeder is not empty, or 2) Verify that the solenoid valve on the feeder is not stuck open.
5. *Sensor tip is dirty:* Clean according to maintenance instructions.

E. Display and LEDs off

1. *No power supply:* Check circuit breaker and/or controller fuse protecting the transformer.

F. Feeder not operating

1. *No Flow:* Flow light LED must be on.

2. *Inadequate Flow*: Check flow through flow cell and controller.
3. *Blown output fuse in the controller*: Replace fuse.

G. Flow LED off

1. Verify that all appropriate valves are open.
2. Verify that there is sufficient pressure in the line. Close right side valve slightly if necessary.
3. Verify that the flow switch is securely connected to the controller terminals.
4. Both the pH and ORP dose outputs are disabled if the green Flow LED is not illuminated.

V. Warranty

IPS-M720 pH/ORP Controllers

IPS Controllers warrants the IPS-M720 controller to be free of defects in materials and workmanship for a period of five (5) years from the date of installation. This warranty is limited to the repair or replacement of defective components (at our discretion) when returned to the factory within the five (5) year warranty period.

Other Components

IPS Controllers warrants all other components including flow cells and flow switches for a period of one (1) year from the date of installation. Sensors will be under warranty for a period of one (1) year from the date of factory purchase. This warranty is limited to the repair or replacement of defective components (at our discretion) when returned to the factory within the one (1) year warranty period.

Limitation of Liability

This Limited Warranty excludes liability for any damage during transportation, consequential damages of any kind, damages due to improper installation or improper operation, improper handling of chemicals, and the use of this product in applications for which it was not designed.

Claims

All warranty claims should be directed to IPS Controllers at the contact point listed below. After receiving a Returned Merchandise Authorization (RMA) number, all product must be returned (shipping prepaid) to the factory for evaluation.



Simply intelligent water care.

Factory Contact:

30826 Wealth Street, Murrieta, CA 92563
phone. 877-693-6903, fax. 951-693-3224
www.ipscontrollers.com